

Heavy Duty Torque Wheel

Model TW-2T-60K-S

- 60,000 lb-ft (81 kN-m) capacity
- Measures combined drive and braking torque of one or two tires
- Adapts to 19.5 inch and larger wheels
- Environmentally protected
- Rugged stainless steel construction
- Temperature compensated
- Consistent sensitivity among all units
- Configured to minimize magnetic sensitivity



Description

The *TW-2T-60K-S Wheel Torque Transducers* are suitable for class 8 trucks, agricultural and construction equipment, and other large vehicles. One transducer will measure the combined torque load for a dual-wheel set or a single tire. It mounts onto the vehicle using custom designed adapters which duplicate the critical dimensions of the production wheel and place the tires on the production centerline. Being rugged and waterproof, they are capable of on-road and off-road measurements in all conditions.

The *TW-2T-60K-S* measures all torque developed between the tire patch and the vehicle hub and can be used for drivetrain development to study efficiency and for optimal component design. They are also ideal for brake system component development, as well as anti-lock brake development, traction control, and vehicle stability system design. Measured data can be used for component development, computer modeling, and laboratory simulation and validation.

Specifications

Full Scale Measurable Load	60,000 lb-ft (81 kN-m)
Maximum Load Capacity (My)	60,000 lb-ft (81 kN-m)
Maximum Static Vertical Load Capacity	13,480 lb (6,100 kg)
Sensor	4 arm strain gauge bridges
Nonlinearity	≤ 1% of full scale output
Hysteresis	< 0.5% of full scale output
Temperature Range, Operating	-40°F to 257°F (-40°C to 125°C)

8500 Ance Road
Charlevoix, MI 49720
Tel: 231-547-5511
Fax: 231-547-7070
03-10-20
Rev. A

MICHIGAN SCIENTIFIC
corporation

<http://www.michsci.com>
Email: muserinfo@michsci.com

321 East Huron Street
Milford, MI 48381
Tel: 248-685-3939
Fax: 248-685-5406

Heavy Duty Torque Wheel

TW-2T-60K-S Configuration

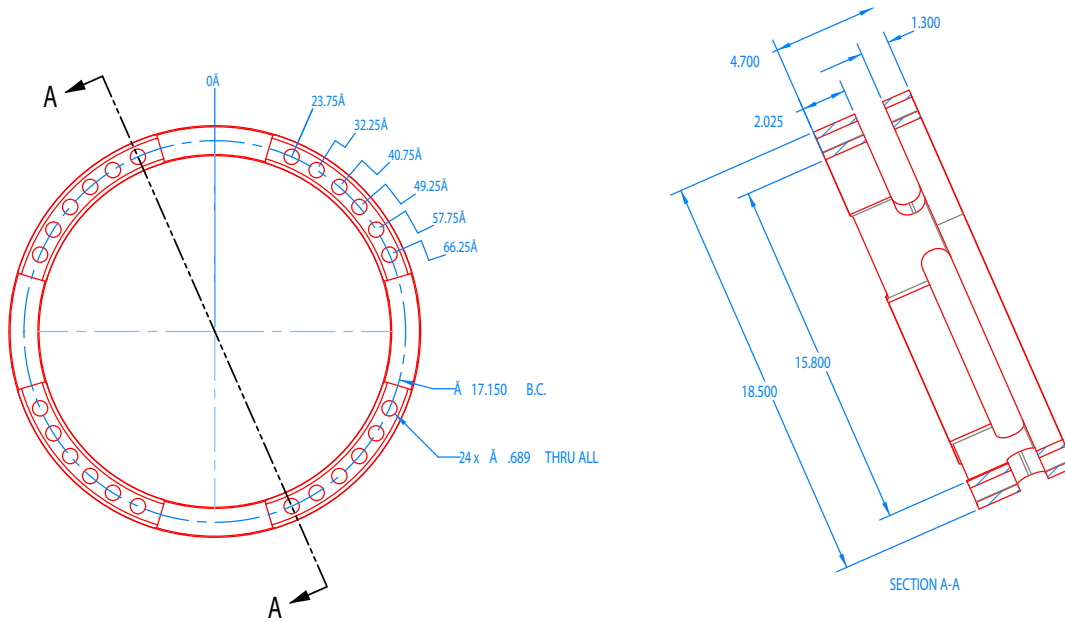

Details and specifications provided in this document are purely for informational purposes and are subject to alterations. No liability is accepted for errors or omissions.
©2020 Michigan Scientific Corporation

Ordering Options

Michigan Scientific offers a fully weatherproof slip ring, encoder, and amplifier instrumentation assembly to be used with all *Wheel Torque Transducers*. Refer to the Instrumentation Assemblies section for more information.

8500 Ance Road
Charlevoix, MI 49720
Tel: 231-547-5511
Fax: 231-547-7070
03-10-20
Rev. A

MICHIGAN SCIENTIFIC
corporation
<http://www.michsci.com>
Email: mscinfo@michsci.com

321 East Huron Street
Milford, MI 48381
Tel: 248-685-3939
Fax: 248-685-5406